

# **Diocese of Davenport**



**8<sup>th</sup> Grade**

**Science  
Diocesan  
Assessment**

**March 2007**

The page left blank intentionally.

**DIRECTIONS:**

The following test has multiple choice and short answer questions over science concepts you have learned during this year and past years.

On the multiple choice questions please review all of the choices and select the one you think best answers the question. On the separate answer sheet, fill in the circle of the answer you chose. See sample.

Short answer questions are located on the answer sheet and need to be answered to complete the test. Use complete sentences when responding to these short answer questions.

**SAMPLE QUESTION:**

- 1. Which of these would you find growing in a desert?
  - A. A maple tree
  - B. A dandelion
  - C. A cactus
  - D. A corn plant

**SAMPLE** Please completely fill in the circles that best represent your responses. Fill in marks like this: ● not like this: ◐ ⊗

1.	Ⓐ	Ⓑ	●	Ⓓ	34.	Ⓐ	Ⓑ	Ⓒ	Ⓓ	67.	Ⓐ	Ⓑ	Ⓒ	Ⓓ
2.	Ⓐ	Ⓑ	Ⓒ	Ⓓ	35.	Ⓐ	Ⓑ	Ⓒ	Ⓓ	68.	Ⓐ	Ⓑ	Ⓒ	Ⓓ
3.	Ⓐ	Ⓑ	Ⓒ	Ⓓ	36.	Ⓐ	Ⓑ	Ⓒ	Ⓓ	69.	Ⓐ	Ⓑ	Ⓒ	Ⓓ
4.	Ⓐ	Ⓑ	Ⓒ	Ⓓ	37.	Ⓐ	Ⓑ	Ⓒ	Ⓓ	70.	Ⓐ	Ⓑ	Ⓒ	Ⓓ
5.	Ⓐ	Ⓑ	Ⓒ	Ⓓ	38.	Ⓐ	Ⓑ	Ⓒ	Ⓓ	71.	Ⓐ	Ⓑ	Ⓒ	Ⓓ
6.	Ⓐ	Ⓑ	Ⓒ	Ⓓ	39.	Ⓐ	Ⓑ	Ⓒ	Ⓓ	72.	Ⓐ	Ⓑ	Ⓒ	Ⓓ

**CODES:**

Bettendorf Lourdes	01
Burlington Notre Dame	02
Centerville St. Mary's	03
Clinton Prince of Peace	04
Dav. Assumption	05
Dav. All Saints	06
Dav. JFK	07
Dav. St. Paul the Apostle	08
Dewitt St. Joseph	09
Dav. Holy Trinity	10
Iowa City Regina	11
Keokuk Catholic	12
Muscatine Bish. Hayes	13
Ottumwa Seton	14
Washington St. James	15

The page left blank intentionally.

## Section 1

- Why do mountain climbers use oxygen equipment at the top of the world's highest mountains?
  - There is less oxygen in the air at great heights.
  - There is little nitrogen in the air at great heights.
  - There is a hole in the ozone layer.
  - There is no air at the top of very high mountains.
- Which of the following best explains why the pressure inside a high-flying airplane must be controlled?
  - At high altitudes there is greater atmospheric pressure than on the surface of the Earth.
  - At high altitudes there is lower atmospheric pressure than on the surface of the Earth.
  - If the cabin is not pressurized, ozone and other upper atmospheric gases will enter the air plane.
  - If the cabin is not pressurized, carbon dioxide will escape from the airplane.
- What is predicted to be a result of global warming?
  - Rising ocean level
  - More severe earthquakes
  - Larger volcanic eruptions
  - Thinning ozone layer
- Which of the following is an important factor in explaining why seasons occur on Earth?
  - Earth rotates on its axis.
  - The Sun rotates on its axis.
  - Earth's axis is tilted.
  - The Sun's axis is tilted.
- Which answer best reflects how volcanic eruption affects the Earth's climate?
  - There is no affect on the climate.
  - The climate will cool.
  - The climate will warm.
  - There will be more hurricanes.
- Clouds form when
  - water evaporates
  - air pressure increases
  - water vapor condenses
  - humidity decreases
- What property of water is most important for living organisms?
  - It is odorless.
  - It does not conduct electricity.
  - It is tasteless.
  - It is liquid at most temperatures on Earth.

8. This picture shows the three layers of the Earth.

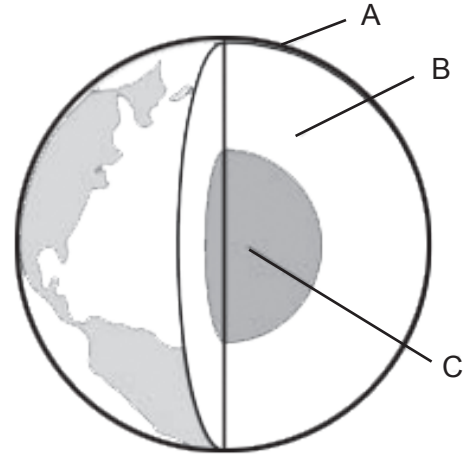

Where is the hottest?

- Layer A
  - Layer B
  - Layer C
  - All three layers are the same temperature.
9. Which layer in the diagram contains the most organic material?

### Diagram of soil layers

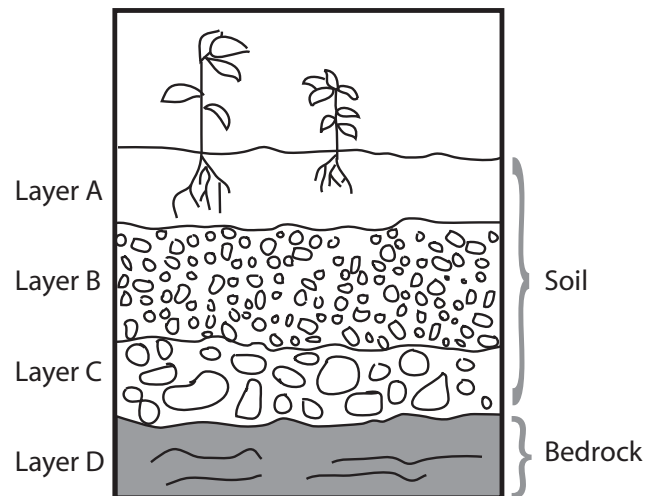

- Layer A
  - Layer B
  - Layer C
  - Layer D
10. Rain and running water can wash away soil. From which area is soil most likely to be washed away?
- A sloping area with bushes
  - A flat area with grasses
  - A flat area that is barren
  - A sloping area that is barren

11. Which BEST describes the movement of the plates that make up Earth's surface over millions of years?
- They moved for millions of years but have now stopped.
  - They stayed the same for millions of years but are now moving.
  - They have been continually moving.
  - They have never moved.
12. The Moon produces no light, and yet it shines at night. Why is this?
- The Moon reflects the light from the Sun.
  - The Moon rotates at very high speed.
  - The Moon is covered with a thin layer of ice.
  - The Moon has many craters.
13. The Earth's Moon is
- always much closer to the Sun than it is to the Earth
  - always much closer to the Earth than it is to the Sun
  - about the same distance from the Sun as it is from the Earth
  - sometimes closer to the Sun than it is to the Earth and sometimes closer to the Earth than it is to the Sun
14. What is true about the brightness of stars?
- The closer the star is, the brighter it appears.
  - Brighter stars have hotter surface temperatures.
  - Red stars are the hottest and brightest stars.
  - The sun is the brightest star in the universe.
15. In geologic time, which of the following events probably occurred most recently?
- The folding of rock in Layers 3, 4, 5, and 6
  - The erosion of Layer 3
  - The depositing of rock in Layer 1
- I only
  - III only
  - I and II only
  - I, II, and III occurred simultaneously
16. Examination of the rock formation indicates that Rock Layers 3, 4, 5, and 6 are no longer horizontal. What most likely accounted for the bending of the rock layers?
- Figure 1
- Horizontal stretching caused the rock to bend.
  - Pressure from above pushed the rock layers downward at Point Z.
  - The layers of rock were deposited unevenly.
  - Both vertical and horizontal pressures produced the bending.
17. Fool's gold is found in Layer C but not in Layers A, B, D, E, or F. Which other layer might contain fool's gold?
- Layer 1
  - Layer 2 only
  - Layer 3 only
  - Both Layers 1 and 2 only
18. In science class, you learned that each layer of rock is older than the one directly above it. Which of the following rock layers is probably the oldest?
- A
  - B
  - D
  - F
19. The event that occurred along Line XY is most appropriately described as:
- erosion
  - faulting
  - sedimentary deposition
  - volcanic eruption
20. Layers E and F have similar chemical properties but very different physical properties or characteristics. Which of the following factors most probably caused these physical differences?
- Erosion only
  - Weathering only
  - A combination of heat and pressure
  - Penetration by tree roots

## Section 2 — Cliff Face

While on vacation, a student in your class took a picture of an interesting cliff face. Figure 1 below represents the geologic cross section of that cliff face. Use the figure to answer questions 15–20.

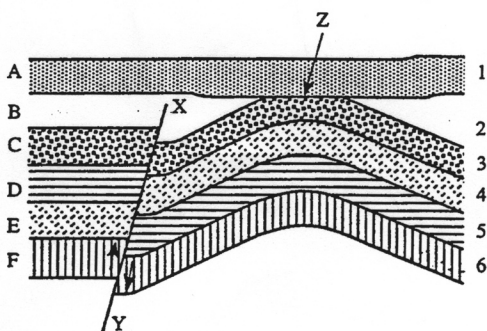

## Section 3 — Weather Maps

Weather maps appear in most daily newspapers and as part of television news programs. Although weather maps do not always contain the same information, they usually have several common features. Temperatures at many locations, precipitation, weather fronts, and pressure areas can be found on most maps. A weather map is shown in the figure below.

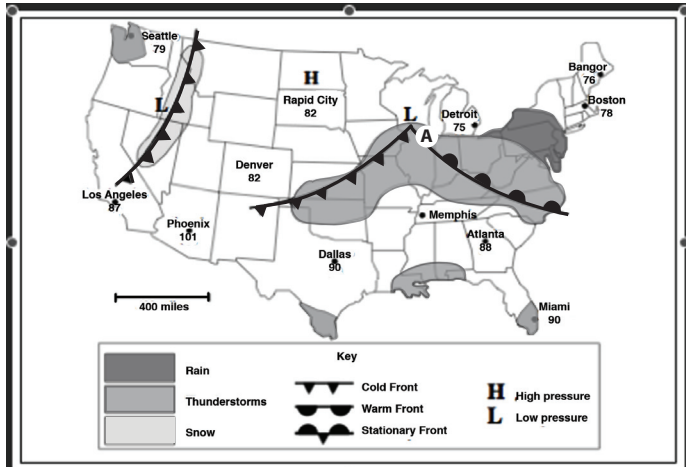

21. According to the weather map shown, which of the following cities is receiving precipitation?
  - A. Detroit
  - B. Rapid City
  - C. Bangor
  - D. Seattle
22. Which of the following best describes the weather along the frontal boundary lines shown in the map?
  - A. Clear and sunny
  - B. Cloudy but no precipitation
  - C. Thunderstorms
  - D. Windy but clear
23. In the Northern Hemisphere, winds circulate in counter-clockwise direction around low pressure systems. Given this, one would expect that the winds in Chicago (Point A on the map) are most likely out of the:
  - A. east
  - B. north
  - C. southwest
  - D. northeast
24. When a warm air mass meets a cold air mass, the warm air mass:
  - A. rises above the cold air mass because cold air is more dense than warm air.
  - B. rises above the cold air mass because cold air is less dense than warm air.
  - C. sinks below the cold air mass because cold air has the same density as warm air.
  - D. sinks below the cold air because cold air holds more water vapor than warm air.

## Section 4 Rocks

There are three different types of rocks. Variations in rocks occur because of the rock cycle. Figure 1 contains a diagram of the rock cycle. Use Figure 1 to answer the following questions.

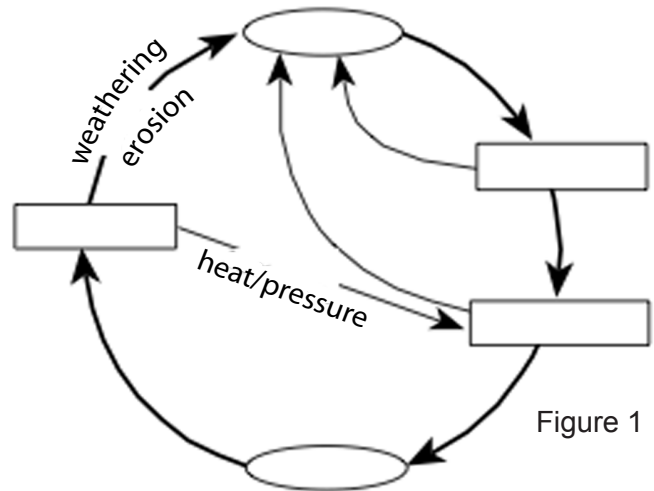

Figure 1

25. According to Figure 1, each rock type can:
  - I. provide material for another rock type.
  - II. result from another rock type.
  - III. be changed by forces at Earth's surface or within Earth's crust.
  - A. I and II only
  - B. I and III only
  - C. II and III only
  - D. I, II, and III
26. Typically, sedimentary rocks are formed:
  - A. below Earth's surface as magma.
  - B. only in volcanoes.
  - C. only under great pressure.
  - D. from materials that settle.
27. The formation of metamorphic rocks depends on all of the following except:
  - A. the composition of the parent rocks.
  - B. Earth's magnetic field.
  - C. temperature.
  - D. pressure.
28. According to Figure 1, which of the rock types can be formed directly from either of the other two types?
  - A. Igneous
  - B. Metamorphic
  - C. Sedimentary
  - D. Any type can be formed directly from either of the other two types.

29. When rocks undergo weathering, they become:
- magma.
  - igneous rocks.
  - sediments.
  - volcanic cones.
30. Sedimentary rocks can be converted into magma by undergoing which of the following processes?
- Weathering and erosion, followed by melting
  - Weathering and erosion, followed by cooling and crystallization
  - Heat and pressure, followed by melting
  - Melting, followed by cooling and crystallization

34. For which of the following planets is the period of rotation closest to the period of revolution?
- Mercury
  - Saturn
  - Jupiter
  - Venus
35. Based on the data for all the planets excluding Mercury, as the average distance from the Sun increases, the average surface temperature:
- increases.
  - decreases.
  - is unchanged.
  - increases, then decreases.
36. The Star Trek expedition continued to a second star system that contained four planets. The planets, arranged in order of increasing distance from the central star, were Planets A, B, C, and D. Based on the data in Table 1, arrange the planets in order of increasing period of revolution.
- Planet A, Planet B, Planet C, Planet D
  - Planet B, Planet A, Planet C, Planet D
  - Planet C, Planet B, Planet D, Planet A
  - Planet D, Planet C, Planet B, Planet A

## Section 5 — Star Trek Voyage

A Star Trek voyage in our solar system took probe readings of all of the planets. The probe information is listed in Table 1 below. (One revolution is the length of time required for a planet to make one complete trip around the Sun; one rotation is the length of time required for a planet to make one complete turn on its axis.)

Table 1

Planet	Average distance from Sun (millions of km)		Period of revolution (Earth time)	Period of rotation (Earth time)	Average surface temperature (°C)
Mercury	4,875	58	88 days	59 days	230°
Venus	12,180	108	225 days	243 days	450°
Earth	12,753	149	365 days	24 hrs	10°
Mars	6,786	228	687 days	25 hrs	-50°
Jupiter	142,718	778	12 yrs	10 hrs	-130°
Saturn	120,020	1,449.7	29 yrs	10 hrs	-180°
Uranus	50,500	2,871	84 yrs	18 hrs	-210°
Neptune	45,600	4,497	165 yrs	19 hrs	-220°
Pluto	2,200	5,914	249 yrs	6 days	-230°

Mercury's average temperature is the average of the day and night side temperatures.

31. Which of the following planets has the shortest day (measured in Earth time)?
- Pluto
  - Earth
  - Jupiter
  - Mercury
32. Which of the following planets has the longest year (measured in Earth time)?
- Jupiter
  - Mars
  - Venus
  - Moon
33. Using a scale in which 1 mm is equal to 1 million km, which planet would be 5.8 cm from the Sun?
- Mars
  - Mercury
  - Pluto
  - Neptune

## Section 6 — Dichotomous Key

You and your classmates are exploring your community's nature trail. You have found several spiders and insects, and you want to identify them. Your teacher gives you a flow chart for the organisms that are usually found in this area. Hint: Insects have 6 legs, spiders have 8. To use the chart, always begin at Step 1A. If Step 1A correctly describes some characteristic of the organism, follow the directions. If the description in Step 1A does not apply to the organism, go to Step 1B and follow the directions. Proceed from step to step until you have identified the organism.

1A.	8 legs	.....go to 2
1B.	6 legs	.....go to 3
2A.	Solid gray body	..... Wolf spider
2B.	Black body with yellow spots	.....Garden spider
3A.	Wings	.....go to 4
3B.	No wings	..... Ants
4A.	Multicoloredwings (black and orange)	Monarch butterfly
4B.	clear or transparent wings	.....go to 5
5A.	Fuzy bristles on body	..... Honey bee
5B.	Smooth body covering	.....go to 6
6A.	Long, slender, twig-like body	..... Praying mantis
6B.	Thick body	.....Grasshopper

37. According to the chart, an organism that has 8 legs and is solid gray in color is which of the following organisms?
- A. Garden spider
  - B. Ant
  - C. Honey bee
  - D. Wolf spider
38. According to the chart, an organism that has 6 legs, 2 pairs of transparent wings, and a fuzzy body is most likely which of the following creatures?
- A. Honey bee
  - B. Monarch butterfly
  - C. Wolf spider
  - D. Grasshopper
39. Which of the following characteristics on the chart separates the monarch butterfly from the other insects?
- A. Number of legs
  - B. Body covering
  - C. Color of wings
  - D. Body shape

40. According to the chart, the praying mantis possesses which of the following sets of characteristics?
- A. 8 legs, wings, long slender body
  - B. 6 legs, clear or transparent wings, smooth body covering, long slender body
  - C. 6 legs, no wings, thick body
  - D. 8 legs, wings, fuzzy body covering, long slender body
41. How many of the organisms in the chart have 6 legs and are insects?
- A. 2
  - B. 4
  - C. 5
  - D. 7
42. The flow chart described in the introduction is used to accomplish which of the following tasks?
- A. Identification of all spiders and insects
  - B. Identification of all spiders and insects found in your community
  - C. Identification of insects and spiders commonly found in your community's natural habitat
  - D. Identification of all organisms found in your community's natural habitat

43. Which of the following would be the best model to show the interactions between water and the Sun's heat energy in cycles of precipitation?
- A. A light shines on an aquarium covered with glass, and water droplets form on the inside of the glass.

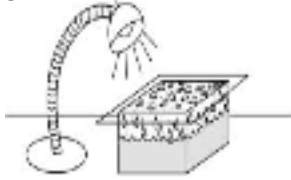

- B. A light shines on a closed cardboard box containing a plant.

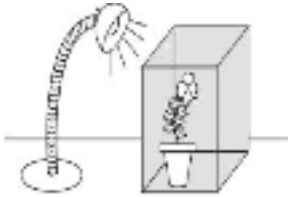

- C. A light shines on a man's face. Droplets of sweat form on his face as he exercises.



- D. A light shines on a glass of iced tea. Water droplets form on the outside of the glass.



## Section 7 — Cars and Kids

Tom's teacher makes a statement that cars and kids have a lot in common when it comes to energy use. They both require fuel input and the output is movement or motion. As each operates, many energy transformations occur. At first, this comparison seems strange to Tom, but as he investigates the statement, he begins to generate some ideas about the similarities and differences. Table 1 below lists some of his ideas.

Characteristic	Cars	Kids
Fuel sources	fossil fuels	plants and animals
Type of energy in fuel	chemical	chemical
How energy is extracted from fuel by cars/kids	combustion	metabolism
Useful products of energy extraction	mechanical energy, heat	chemical energy, mechanical energy, heat
By-products of energy Extraction	exhaust gases, heat	waste (solids, liquids, and gases), heat
Environmental impact if by-products are left untreated	acid rain, smog, airborne particles	pollution of water supplies

44. The gasoline used in a car and the hamburger you ate for lunch have which of the following similarities?
- Both materials contain potential energy stored in their chemical bonds.
  - Both materials have complex compounds containing carbon.
  - The combination of either material with oxygen requires a net consumption of energy.
- A. I only  
 B. III only  
 C. I and II only  
 D. I, II, and III
45. According to Table 1, kids and cars can generate more of a certain product than they need. That product is:
- carbon.
  - oxygen.
  - heat.
  - mechanical energy.

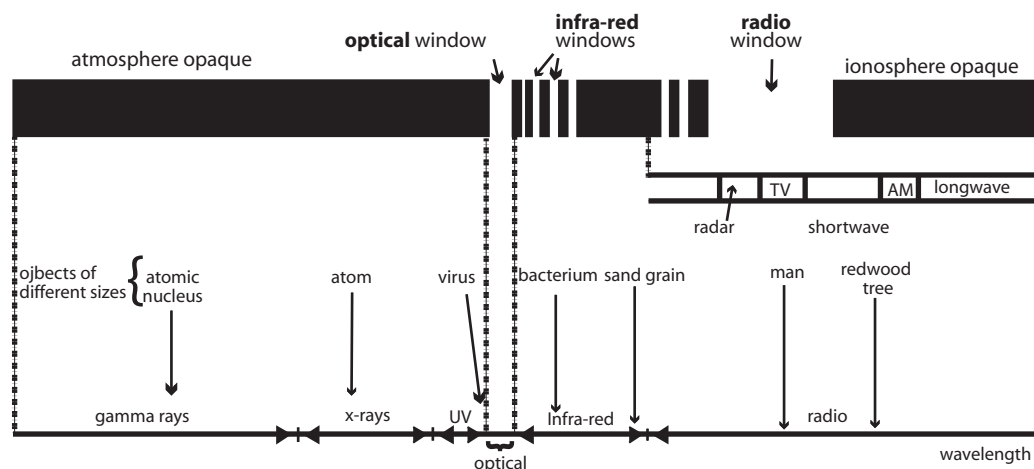

Figure A

46. Both the fuel for cars and food for kids can be linked to green plants. The process in which green plants convert energy from the sun into energy stored in carbon-containing molecules is called:
  - A. respiration.
  - B. combustion.
  - C. digestion.
  - D. photosynthesis.
47. Which of the following materials is consumed by both kids and cars in order to use their fuels?
  - A. Carbon dioxide
  - B. Chlorine
  - C. Hydrochloric acid
  - D. Oxygen
48. The energy stored in the chemical bonds of fossil fuels came from:
  - A. water.
  - B. oxygen.
  - C. sunlight.
  - D. wind energy.
49. Gasoline for cars is produced in oil refineries by the conversion of the large hydrocarbon molecules found in crude oil to smaller molecules. A process that converts large fuel molecules to smaller ones occurs in which of the following organs of the human body?
  - A. Brain
  - B. Kidneys
  - C. Lungs
  - D. Small intestine

## Section 8 - 9

**DIRECTIONS:** After reading the introductory information, you will find six questions. Read each one carefully, then choose the best answer to each question and fill in the correct space on your answer sheet.

### Electromagnetic Spectrum

The light that **we** detect with **our eyes** is called **visible** or **optical** light. Optical light is a form of **electromagnetic radiation**. Electromagnetic radiation, or EM radiation, can be described according to its wavelength or frequency. As the energy of EM radiation increases, its frequency increases and its wavelength decreases. The wavelength of EM radiation can be compared to the size of an object. For example, some infrared wavelengths are comparable of a bacterium, as shown in Figure A

The **electromagnetic spectrum**, or EM spectrum, includes all forms of EM radiation. The EM spectrum extends from very short wavelength (gamma) radiation to very long wavelength (radio) radiation, as shown in Figure A. All of these radiations travel through space at the speed of light. Some wavelengths of EM radiation can pass all the way through Earth's atmosphere, while others cannot. A **window in the spectrum** consists of those wavelengths that can reach Earth's surface from space.

**Study Figure A thoroughly and use the information in answering all six questions.**

50. Optical light is different from radio radiation, in that optical light:
  - A. is a form of EM radiation, while radio radiation is not.
  - B. travels at a higher speed in space than radio radiation.
  - C. cannot travel through the earth's atmosphere, while radio radiation can.
  - D. has a higher energy than radio radiation

51. The concentration of sodium ions in blood is often measured by a technique called flame emission spectroscopy. Sodium ions that are heated in a flame emit yellow light. The wavelength of the yellow light is similar to the size of:
- an atomic nucleus.
  - an atom.
  - a virus.
  - a sand grain.
52. When an AM radio transmitter broadcasts radio waves, the wavelength of the radio radiation will be closest to the size of a:
- bacterium.
  - man.
  - redwood tree.
  - a sand grain.
53. Many types of EM radiation travel through interstellar space and reach the Earth. According to Figure A, which of the following types of EM radiation is most likely to penetrate Earth's atmosphere and reach Earth's surface?
- Gamma rays
  - Radar
  - Longwave radio
  - X - rays
54. Galaxies are collections of hundreds of billions of stars that are bound together by gravity. A galaxy that emits radiation in all portions of the EM spectrum would be most difficult to detect with which of the following telescopes, assuming that the telescopes are located on Earth's surface?
- Optical
  - Infrared
  - Radio
  - Gamma Ray
55. The clarity of an image produced by a telescope at a given wavelength is directly related to the telescope's resolution. The resolution is defined as the ratio of the wavelength of the electromagnetic radiation to the diameter of the telescope. To obtain a given resolution, which of the following types of EM radiation would require the telescope with the largest diameter?
- Infrared radiation
  - Ultraviolet radiation
  - X-rays
  - Gamma rays

## Section 9

56. Tissues are found in living things. What is the definition of a tissue?
- A group of cells with similar structure and function
  - A group of cells with different structure and function
  - A group of organelles contained inside a cell
  - A group of substances that make up the walls of a cell
57. Which of these is NOT a function of the blood?
- Digesting food
  - Protecting against disease
  - Carrying waste materials away from the cells
  - Carrying oxygen to different parts of the body
58. In the human body the digestion of proteins takes place primarily in which two organs?
- Mouth and stomach
  - Stomach and small intestine
  - Liver and gall bladder
  - Pancreas and large intestine
59. The Earth's Moon is
- always much closer to the Sun than it is to the Earth
  - always much closer to the Earth than it is to the Sun
  - about the same distance from the Sun as it is from the Earth
  - sometimes closer to the Sun than it is to the Earth and sometimes closer to the Earth than it is to the Sun
60. If air pollution causes the rain that falls on this pond to become much more acidic, after two years how will this acidity affect the living things in this pond?
- There will be more plants and animals because the acid is a source of food.
  - There will be fewer plants and animals because the acid will dissolve many of them.
  - There will be fewer plants and animals because many of them cannot survive in water with high acidity.
  - There will be more plants and animals because the acid will kill most of the disease-causing microorganisms.

61. Which living things in the pond system break down dead plants and animals?
- Green algae
  - Bacteria
  - Rushes
  - Frogs
62. All of the following would be helpful in separating a mixture of sand and salt EXCEPT
- a magnet
  - a glass cup
  - a filter paper and funnel
  - water
63. To keep a heavy box sliding across a carpeted floor at constant speed, a person must continually exert a force on the box. This force is used primarily to overcome which of the following forces?
- Air resistance
  - The weight of the box
  - The frictional force exerted by the floor on the box
  - The gravitational force exerted by the Earth on the box
64. What property of water is most important for living organisms?
- It is odorless.
  - It does not conduct electricity.
  - It is tasteless.
  - It is liquid at most temperatures on Earth.
65. What feature is shared by ALL insects?
- External skeleton
  - Two pairs of wings
  - Jumping legs
  - Stinging mechanism
66. Which statement best explains why mammals are found in very cold regions of the world but lizards are not?
- Both mammals and lizards are cold-blooded, but mammals have fur to keep them warm.
  - Both mammals and lizards are warm-blooded, but lizards get too cold when they shed their skin.
  - Since mammals, but not lizards, are warm blooded, their body temperature will adjust to match the external temperature.
  - Since mammals, but not lizards, are warm blooded, they will maintain their body temperature using heat from metabolic processes.
67. Why would a scientist insist that all objects have a gravitational force?
- Because all objects are matter, all matter has mass and all mass has gravity.
  - Because all objects have some energy and energy has gravity.
  - Small objects do not have gravity, but large objects do because they have matter.
  - Only objects that have electrical or radiation energy have gravity.
68. Which group is most responsible for the recycling of atoms within the environment?
- Autotrophs
  - Consumers
  - Phototrophs
  - Decomposers
69. Which of the following is designed to convert energy into mechanical work?
- Electric fan
  - Kerosene heater
  - Flashlight
  - Baking oven
70. This diagram represents water in a container. What process is taking place?

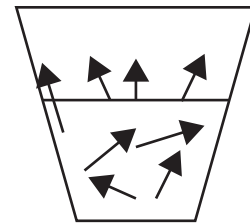

- Freezing
  - Condensation
  - Melting
  - Evaporation
71. Choose the best answer that explains why comets have tails, but asteroids do not.
- Comets are asteroids that get too close to the sun, and have bits of rock and ash blown off of them by the solar wind.
  - Asteroids do have tails, we cannot see them because they are so faint.
  - Comet tails are not a physical substance. It is a byproduct of reflected light from the sun.
  - Comets are mostly ice and asteroids are mostly rock. The ice is blown off by the solar wind, but the rock is not.

72. Which technology contributed to the development of the cell theory?
- Organic stains
  - Compound microscopes
  - Heat-resistant glassware
  - Adjustable gas burners



73. The picture shows a student reading a graduated cylinder. Which change would help ensure that a more accurate measurement is made?
- The student should be seated.
  - The cylinder should be held with two hands.
  - The student should be wearing insulated gloves.
  - The cylinder should be on a flat surface.
74. Which of these researchers would be most interested in maintaining a healthy deciduous forest?
- Biochemist
  - Sonographer
  - Toxicologist
  - Ecologist

## Section 10 — Sound

Sound is a form of energy produced by the vibration of matter. Sound travels in waves through matter. The table below shows the speed of sound through various substances.

Substance	Speed (m/sec)
Rubber	60
Brick	3,650
Cork	500
Stone	5,971
Air at 0 °C	331
Air at 25 °C	346
Water at 25°C	1,498

Scientists describe sounds by their loudness, pitch, and rhythm or pattern. Most scientists and musicians agree that pleasant sounds such as music have a definite, predictable rhythm and pitches that are pleasing to hear.

Use these ideas to answer the following questions.

75. A lightning flash produces thunder at the same time the lightning flash occurs. Which of the following best explains why we see the lightning before we hear the thunder?
- Lightning is produced by static electricity.
  - The speed of light is greater than the speed of sound.
  - Lightning is more dangerous than thunder.
  - The speed of sound is decreased by rain or humidity.
76. A magazine article claims that the speed of sound through a gas is always lower than the speed of sound through a solid. Is this statement supported by the data in the table?
- Yes, because the speed of sound through all the solids in the table is always higher than the speed of sound in air.
  - Yes, because the speed of sound through ice is higher than the speed of sound through air.
  - No, because the speed of sound through rubber is lower than the speed of sound through air.
  - No, because the speed of sound through stone is lower than the speed of sound through air.
77. According to the table, the speed of sound through air increases as the:
- density of the air increases.
  - temperature of the air increases.
  - loudness of the sound increases.
  - pitch of the sound increases.
78. String instruments produce sound when the strings are stretched and made to vibrate. If the four strings described below are all the same length, which would most likely produce the highest pitched sound?
- A thick string stretched loosely
  - A thin string stretched loosely
  - A thick string stretched tightly
  - A thin string stretched tightly

## Section 11 — Fly Away

Many factors are involved in the takeoff of an airplane. Starting from rest, the airplane's inertia (the tendency of a motionless plane to remain at rest in the absence of an unbalanced force), must be overcome by the engines' thrust. This is the force that pushes airplanes forward when the propeller or jet engine pushes air backward. Once the airplane starts to move forward, air's resistance to the plane's motion creates a drag force. The drag force increases as the speed of the airplane increases.

While the plane is moving forward, the air moving over the wings divides. Part of the air goes over the wing and part of the air goes under the wing (see Figure A). Because of the shape of the wing, the air going over the wing moves at a higher speed than the air going under the wing. The air with the higher speed exerts a lower pressure on the wing's surface than the air with the lower speed. The difference in pressure produces a force, called lift, that causes the airplane to leave the ground and gain altitude.

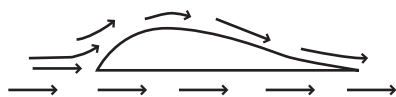
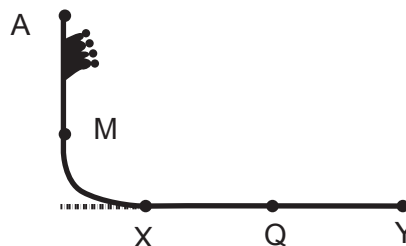

Figure A

79. For the airplane to lift off of the runway, the lift force must exceed which of the following forces?
- Drag
  - Friction
  - Gravity
  - Thrust
80. For an airplane to move at a constant horizontal speed, which of the following forces must balance each other?
- Drag and friction
  - Drag and thrust
  - Friction and lift
  - Lift and thrust
81. When a rocket burns its fuel, an exhaust gas is produced that is ejected from the rocket through a nozzle. The thrust force that propels the rocket upward is the same as which of the following forces?
- The force exerted by air molecules on the rocket
  - The force exerted by air molecules on the exhaust gas
  - The force exerted by the exhaust gas on the air molecules
  - The exerted by the exhaust gas on the rocket

## Section 12 — Physics in Action

The amusement park ride in the diagram below drops the car in which the rider is riding. The ride between Points A and X is frictionless. The rider is in free-fall for 2 seconds and reaches top speed at Point X. A constant braking system operates between Points X and Y, bringing the rider to a complete stop at Point Y.



82. Which of the following graphs best represents a rider's velocity while moving in free-fall from

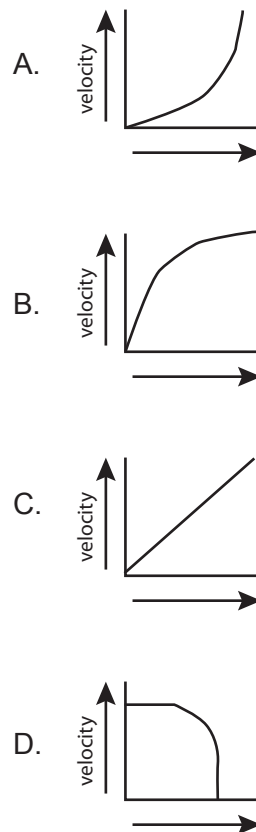

Point A to Point M?

83. Consider a rider moving from Point X to Point Y. The rider's distance from Point X over time is best illustrated by which of the following graphs?

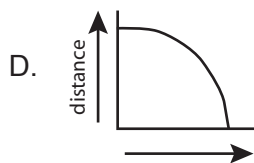
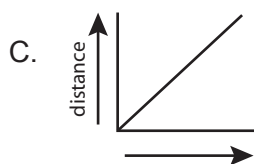
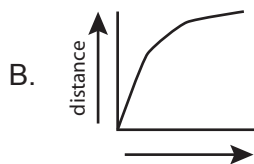
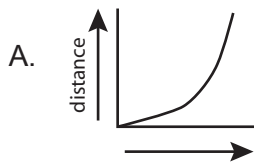

Mary wanted to get a current flow through the galvanometer circuit with a single magnet. To do this, she could:

- A. shine a beam of light on the magnet.
- B. place the stationary magnet far away from the coil.
- C. have the stationary magnet inside the coil.
- D. move the magnet through the coil.

85. After Mary got a current to flow through the galvanometer circuit, the galvanometer registered a reading of 5. Next, she found a second magnet that was identical to the first. She joined the two magnets together, as shown in Figure 2 below.



Using the two joined magnets, she repeated the procedure discussed in Question 1. Mary most likely obtained which of the following galvanometer readings?

- A. Approximately 0
- B. Less than 5
- C. More than 5
- D. Cannot be determined from the information given

### Section 13 — Electromagnets

Mary and her friends were walking by a junkyard when they noticed a crane (a large machine used to lift heavy objects) picking up a car with an electromagnet. (An electromagnet is an object that becomes magnetic when electrified.) Mary was amazed. She wanted to find out how the electromagnet worked, so she conducted some experiments.

84. Mary connected a coil of wire to a galvanometer (a device used to measure small amounts of electrical current), as shown in Figure 1.

Figure 1

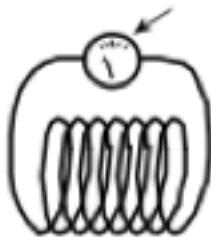

Mary read in her science book that an electromagnet can be made from a coil of wire, a material placed inside the coil of wire (a *core*), and a battery. She assembled an electromagnet and used it to lift paper clips, as shown in Figure 3.

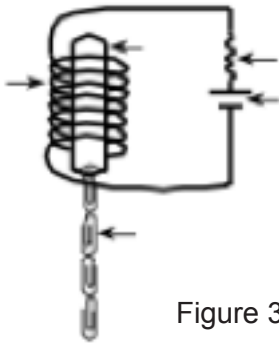

Figure 3

She collected the data shown in Table 1.

Table 1

Experiment				
Factors affecting magnetic field strength	A	B	C	D
No. of coils in wire	10	10	20	20
Type of core	pencil	nail	nail	nail
Battery voltage	6 volts	6 volts	6 volts	12 volts
Number of paper clips lifted at one time	5	9	17	31

86. What can be concluded from the table above about the effect of the type of core on the strength of the magnetic field?
- A coil with a nail core contained a stronger magnetic field than the same coil with a pencil core.
  - A coil with a nail core contained a weaker magnetic field than the same coil with a pencil core.
  - A coil with a nail core contained the same magnetic field as the same coil with a pencil core.
  - The type of core had no effect on strength of the magnetic field.
87. Based on the data in Table 1, which of the following procedures should Mary follow to increase the strength of a magnetic field?
- She should increase both the number of coils and the voltage.
  - She should increase the number of coils and decrease the voltage.
  - She should decrease the number of coils and increase the voltage.
  - She should decrease both the number of coils

and the voltage.

88. Based on the data in Table 1, which of the following procedures most likely will produce the greatest increase in the strength of the magnetic field?
- In Experiment A, changing the pencil core to a nail core
  - In Experiment B, increasing the number of coils from 10-20
  - In Experiment C, changing the number of coils from 20 to 10
  - In Experiment D. Changing the battery voltage from 12 to 6
89. In Experiment B, suppose Mary increased the voltage from 6 to 9. How many paper clips might she expect to attract?
- Less than 5
  - Between 5 and 8
  - Exactly 9
  - More than 9

## Section 14 — Building Blocks of Life

Genetics is the study of the passage of traits from parent to offspring. Traits are determined by pairs of gene forms called *alleles*. Each parent possesses two alleles for each trait. Each parent passes on a copy of one of the alleles to their offspring.

To help determine the possible allele combinations in offspring when two parents mate, a diagram called a Punnett Square is used. The parents' alleles are written on the left side and top of the Punnett Square. The possible allele pairings in the offspring are shown inside the squares. Dominant alleles are represented by a capital letter; recessive alleles are represented by lower case letters. Recessive traits are only observed if both of the alleles of the individual are recessive. Dominant traits are observed when one of the alleles of the individual is dominant.

The following Punnett Squares show the inheritance of hair color in hamsters.

Key: B = Black hair b = White hair

**Punnett Square 1**

	<b>B</b>	<b>b</b>
<b>B</b>	<b>BB</b>	<b>Bb</b>
<b>b</b>	<b>Bb</b>	<b>bb</b>

**Punnett Square 2**

	<b>b</b>	<b>b</b>
<b>B</b>	<b>Bb</b>	<b>Bb</b>
<b>B</b>	<b>Bb</b>	<b>Bb</b>

90. What percentage of the offspring in Punnett Square 1 will have white hair?
- 25%
  - 50%
  - 75%
  - 100%
91. What percentage of the offspring in Punnett Square 2 will have black hair?
- 0%
  - 25%
  - 50%
  - 100%
92. If you crossed a black haired hamster (BB) with a hybrid hamster (Bb) the offspring would be:
- all white
  - all grey
  - all black

D. both black and white

93. In humans, unattached ear lobes (A) is dominant to attached ear lobes (a). Which of the following allele combinations would produce unattached ear lobes?
- AA only
  - aa only
  - Aa and AA only
  - Aa and aa only

## Section 15

94. In which would you expect to find a large number of stars?
- The solar system
  - The rings of Saturn
  - The asteroid belt
  - The Milky Way Galaxy
95. The green color of the copper coating that covers the Statue of Liberty is different from the color of a typical penny. What caused the Statue of Liberty's copper coating to turn green?
- Copper corrodes when exposed to air, creating copper carbonate.
  - Erosion wore away the outer layer of copper, exposing its copper carbonate interior.
  - Copper exposed to air and moisture forms hydrated iron (III) oxide.
  - Copper exposed to air produces a protective carbonate covering.
96. Choose the best answer that explains what makes the Earth unique in the solar system.
- It's the only planet with life.
  - It's the only planet with seasons.
  - It's the only planet with an atmosphere.
  - It's the only planet with volcanic activity.

97. The diagrams show sealed containers, each of which contains a different substance. Which of these diagrams represents the molecules of a gas?

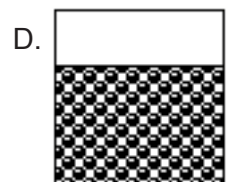
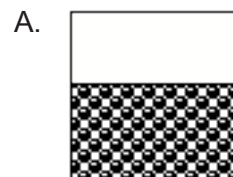

98. What is a major cause of variation within a species?
- Sexual reproduction
  - Asexual reproduction
  - Extinction
  - Photosynthesis

99. The table below shows the symptoms of some diseases that are caused by bacteria.

Disease	Symptoms
Botulism	Vomiting, abdominal pain, coughing, muscular weakness, visual disturbance
pneumonia	Inflammation of lungs, shortness of breath, fluid in lungs
Typhoid fever	Red rashes, high fever, intestinal bleeding
tetanus	Uncontrolled contractions of voluntary muscles

100. Which 2 diseases listed in the table affect the digestive system?
- botulism and typhoid fever
  - botulism and pneumonia
  - tetanus and pneumonia
  - tetanus and typhoid fever
101. Which of the following statements is not part of the cell theory?
- All living things are composed of one or more cells.
  - Cells are the basic unit of structure and function in living things.
  - Cells come only from existing cells.
  - Plants and animals are the only living things made of cells.
102. All of your body's senses work together to maintain\_\_\_\_\_.
- Balance
  - Body weight
  - Homeostasis
  - Taste
103. How does shivering best help the human body?
- It exercises our muscles.
  - It helps us keep cold.
  - It exercises our bones.

D. It helps us keep warm.

104. If two different animal species of the same genus reproduce, then\_\_\_\_\_.
- (For example a horse and a donkey.)
- Their offspring will be unable to reproduce.
  - Their offspring will be the same species as the father.
  - Their offspring will be the same species as the mother.
  - The offspring will be a random mix.

Based on the diagram below, answer questions 105 and 106.

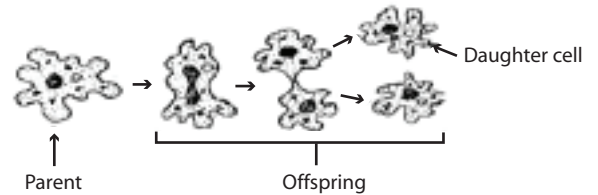

105. What type of reproduction does the diagram show?
- Sexual reproduction
  - Asexual reproduction
  - Genetic engineering
  - Cloning
106. How does the genetic material of the daughter cell compare to the genetic material of the parent cell.
- It has half of the parent cell.
  - It has a fraction of the parent cell.
  - It has the same amount, but different genetic makeup from the parent cell.
  - It has the same amount and the same genetic makeup of the parent cell.